

- HS1 Head Screws M2,5 x 10
- SN1 steel nuts M2,5
- HS2 Head Screws M2,5 x 10
- SN2 steel nuts M2,5
- KL1 Circuit board
- KRM-FDC1-Z80-PCB

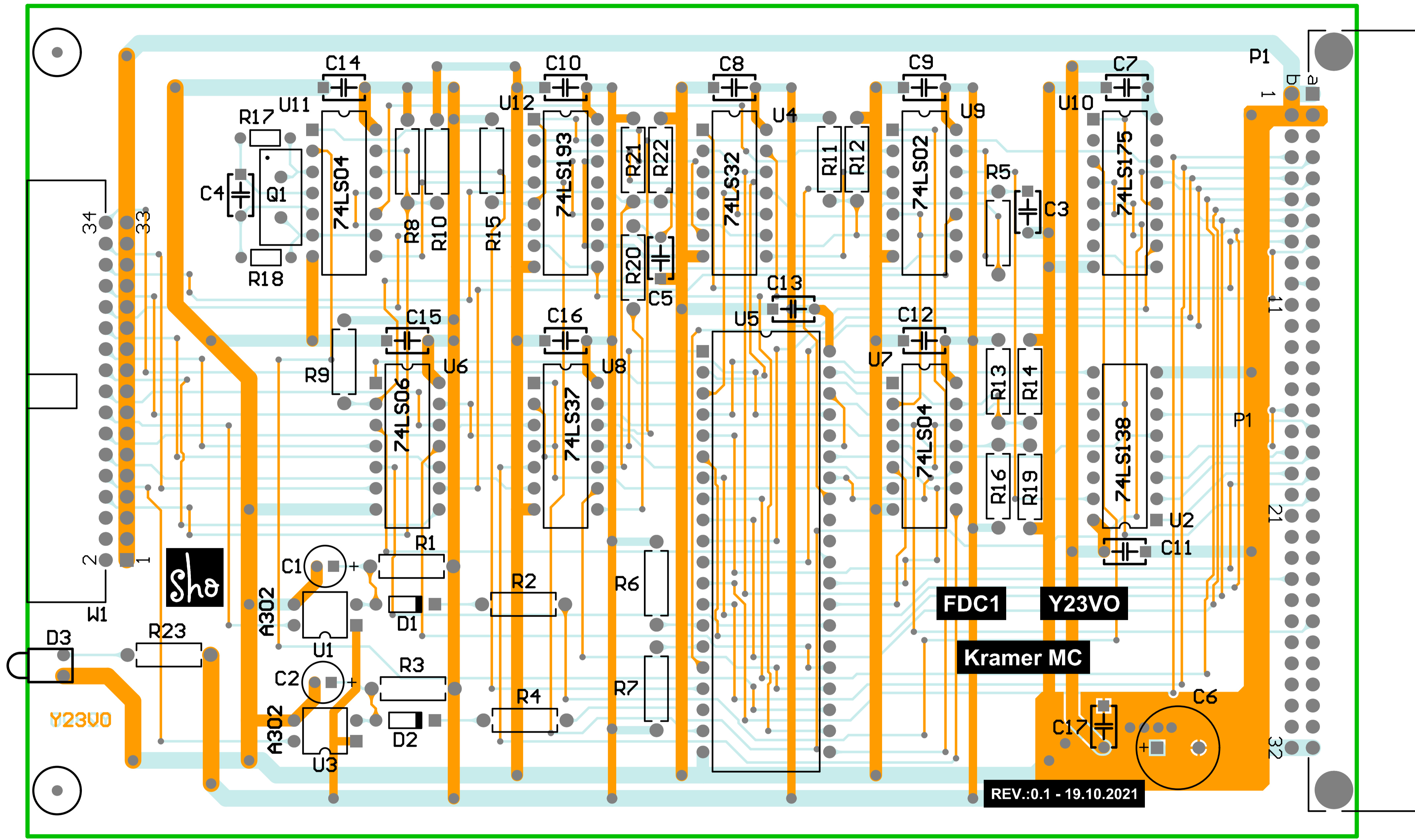



Bearbeiter: S. Hofmann
 Tel: 040 /
 Fax: 040 / 76906856
 Email: shop@shotech.de

Bill of Materials

Datum:	3. Oktober 2023
Zeit:	18:41:37
Variante:	None
Bezeichnung:	Kramer MC Y23V0
Revision:	0.1
Description:	Floppy Controller FDC1

Quantity	Designator	Footprint	Bemerkung	Value	MFT	Order-code	Second-source	shotech
2	C1, C2	CAPPR2-5x11	Elko 22uF 25V 5x11mm RM2	22uF/25V	Capxon	GL220M025C110	001338	1338
1	C3	CAP_Radial_5MM	Vs-Kond 470pF 100V NPO RM5,08 5%	470pF	KEMET	C317C471J1G5TA		2020
1	C4	CAP_Radial_5MM	CAP CER 2,2nF 100V X7R RADIAL	2n2	KEMET	C317C222K1R5TA		2047
1	C5	CAP_Radial_5MM	COG 5% Radial	220pF	KEMET	C317C221J1G5TA		2046
1	C6	CAPPR5-10x12 - RM5	470uF/16V/20%/5000h/RM5.0, ESR 53mR, Ripple 1030mA	470uF/16V	Chang	GK1C471MG125B50CE0		1340
11	C14, C15, C16, C17	CAP_Radial_5MM	100nF/50V/±10%/X7R/RM 5.08	100nF/50V	Vishay / BC Components	K104K15X7RF53H5	C322C104K5R5TA - shotech	1347
1	CS1		Circuit socket DIP40	Circuit socket DIP40	ASS	A 40-LC-TT		1582
2	D1, D2	DO-35	Dioden (Allzweck, Leistung, Schaltung) Vr/75V Io/150mA T/R	1N4148	On Semiconductors	1N4148TR		1594
1	D3	LED-A214B-RED	LED diffus rot 200mcd 25° 3mm	LED-A214B	Everlight	A214B/SUR/S530-A3		2005
2	HS1, HS2		Head Screws M2,5 x 10	Head Screws M2,5 x 10	TR FASTENINGS			2087
1	KL1		Circuit board Kramer MC FDC1	KRM-FDC1-Z80-PCB	frei	KRM-FDC1-Z80-PCB		2380
1	P1	0902164x921	Messerleiste A+B gewinkelt 64polig	A-BM64ABR	Assmann WSW	A-BM64ABR		2021
1	Q1	HC49/4H_SMX	Quarz 4,000 MHz, 30 ppm, 50ppm 16 pF, 130 Ohm	4MHz	HKC	9SL4000000E16F3FZ000		2124
2	R1, R3	RES10-7.8X2.8	WIDERSTAND, 207, axial, 1%	220k	frei			1675
7	R2, R4, R8, R11, R13, R16, R21	RES10-7.8X2.8 - 220R	WIDERSTAND, 207, axial, 1%	220R	frei	RMGE220		1239
2	R5, R20	RES10-7.8X2.8	WIDERSTAND, 207, axial, 10k, 1%	470R	free			1748
1	R6	RES10-7.8X2.8	WIDERSTAND, 207, axial, 1%	4k7				1587
3	R7, R9, R15	RES10-7.8X2.8 - 1k	Metallsch. 0207 1/4W 1%	1k	frei	RMGK001		1235
6	R10, R12, R14, R19, R22, R23	RES10-7.8X2.8 - 330R	WIDERSTAND, 207, axial, 1%	330R				1588
2	R17, R18	RES6.5-3.4X1.9	Metallsch. 0204 1/4W 1%	1k	frei	frei		1255
2	SN1, SN2		steel nuts M2,5	steel nuts M2,5	frei			1872
2	U1, U3	P004-DDR	Threshold Switch	A302D	RFT	A302D	und 2 getauscht !	
1	U2	N016	3-Line to 8-Line Decoder / Demultiplexer	74LS138N	NXP	74LS138N	DS8205D	1540
1	U4	N014	Quadruple 2-Input Positive-OR Gate	SN74LS32N	Texas Instruments	SN74LS32N	DL032D	
1	U5	PDIP40	Single/Double Density Floppy Disk Controller DIP40	UPD765AC	NEC	UPD765AC	U8272	
1	U6	N014	Hex Inverter Buffer / Driver with Open-Collector High-Voltage Outputs	SN74LS06N	Texas Instruments	SN74LS06N		2058
2	U7, U11	N014	Hex Inverter	SN74LS04N	TI	SN74LS04N	DL004D	1549
1	U8	N014	Quadruple 2-Input Positive-NAND Buffer	SN74LS37N	Texas Instruments	SN74LS37N	DL037D	
1	U9	N014	Quadruple 2-Input Positive-NOR Gate	SN74LS02N	Texas Instruments	SN74LS02N	DL002D	
1	U10	N016	Quadruple D-Type Flip-Flop with Clear	SN74LS175N	Texas Instruments	SN74LS175N	DL175D	
1	U12	N016	UP-Down Counter	SN74LS193N	TI	SN74LS193N	DL193D	1174
1	W1	918534x323	W-Stiftleiste 34polig gewinkelt, schwarz	CON-2x17W	SHENZHEN JINLING ELECTRONICS	3210-34RGOCBK00A01		2183